

Recent Rental: 319 STONINGTON RD - \$5,800



Remarks MAGNIFICENT CUSTOM HOME in popular Springbrook Forest on a majestic 1+ acre lot; Fabulous Master BR suite on upper level w/lrg walk-in closets, tray ceiling, lrg sitting/exercise rm w/fpl; Library on upper level; Another MBR suite on entry level; Gourmet Kitchen; 3 fireplaces;

Rooms	Total	Main	Upper 1	Lower 1
Bedrooms	5	1	4	0
Full Baths	5	1	3	1
Half Baths	1	1	0	0

Basic Information

Address 319 STONINGTON RD
City/Town SILVER SPRING
State MD
Zip Code 20902
County MONTGOMERY
Type Detached
MLS# 1002116162

Ownership Other
Style Colonial
Adv Subdivision SPRINGBROOK FOREST
Year Built 2008
Beds 5
Baths 5/1
Lot Size 49,428

Acres 1
Tax Living Area 5,770
Levels 3+
Contract Date 2018-10-22
Close Date 2018-11-01
Close Price \$5,800

Exterior/Construction Features/Utilities

Exterior Stucco
Water Type Public
Sewer Public Sewer

Hot Water Electric
Heating Forced Air, Heat Pump(s)
Cooling Central A/C, Heat Pump(s)

Garage Spaces 2.00
Parking Circular Driveway, Garage

Tax/Legal Information

Tax ID # 161301163864
Legal Subdiv SPRINGBROOK FOREST

Short Sale No
Foreclosure No

REO/Bank Owned No

Interior Features/Amenities

Appliances Cooktop, Dishwasher, Disposal, Dryer, Microwave, Oven - Self Cleaning, Oven - Wall, Refrigerator, Washer, Water Heater

Int. Style Breakfast Area, Kitchen - Gourmet, Dining Area, Entry Level Bedroom, Chair Railings, Upgraded Countertops, Crown Moldings, Primary Bath(s), Window Treatments, Wood Floors, Floor Plan - Open

Entryway Foyer
Wall/Ceiling Tray Ceilings, Cathedral Ceilings, Vaulted Ceilings
Fireplaces 3
Basement Rear Entrance, Fully Finished, Outside Entrance, Daylight, Full
Garage Garage Door Opener



CIMENT & SHIELDS TEAM

Barbara Ciment, Associate Broker



(C) 301-346-9126 (O) 301-424-0900
 barbara@ciment.com www.ciment.com



Recent Rental: 319 STONINGTON RD - \$5,800

Rooms/Levels/Flooring

Breakfast Room	Main	HardWood	Dining Room	Main	HardWood
Foyer	Main	Marble	Great Room	Main	HardWood
Kitchen	Main	HardWood	Living Room	Main	HardWood
Primary Bedroom	Main	HardWood	Bedroom 3	Upper 1	HardWood
Bedroom 4	Upper 1	HardWood	Library	Upper 1	HardWood

Information Courtesy of Long & Foster Real Estate, Inc.. Copyright 2024 Bright MLS. Information is believed to be accurate, but should not be relied upon without verification. Accuracy of square footage, lot size and other information is not guaranteed.



**CIMENT
& SHIELDS** TEAM

Barbara Ciment, Associate Broker



(C) 301-346-9126 (O) 301-424-0900
barbara@ciment.com www.ciment.com



Floor Plans

319 Stonington Rd Silver Spring, MD 20902

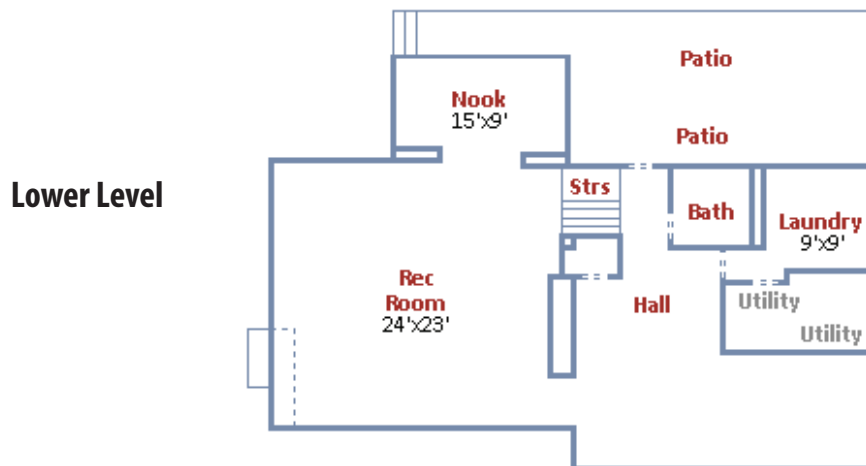
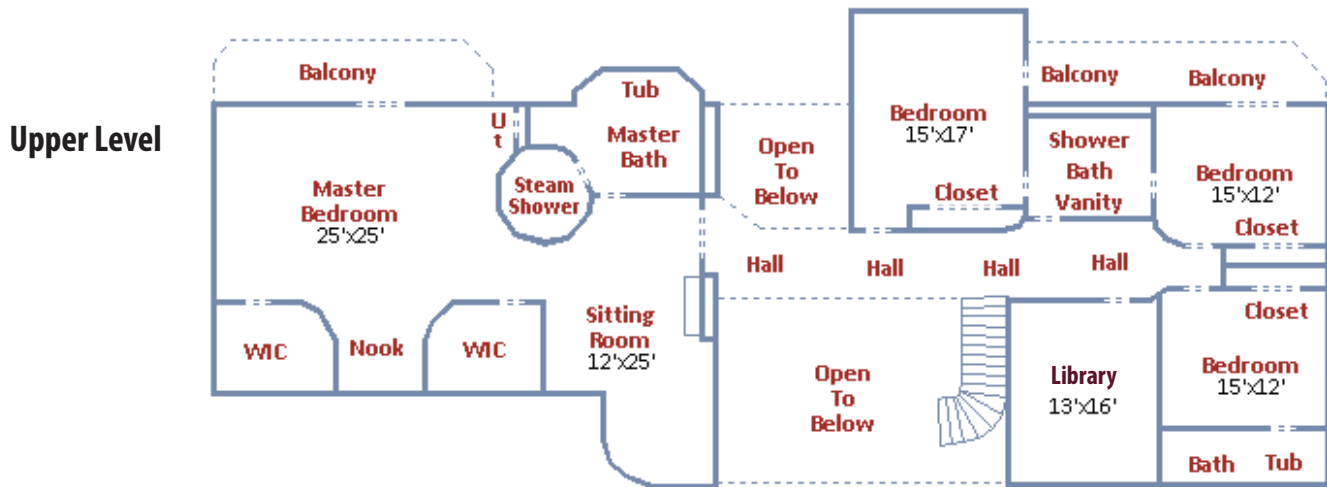
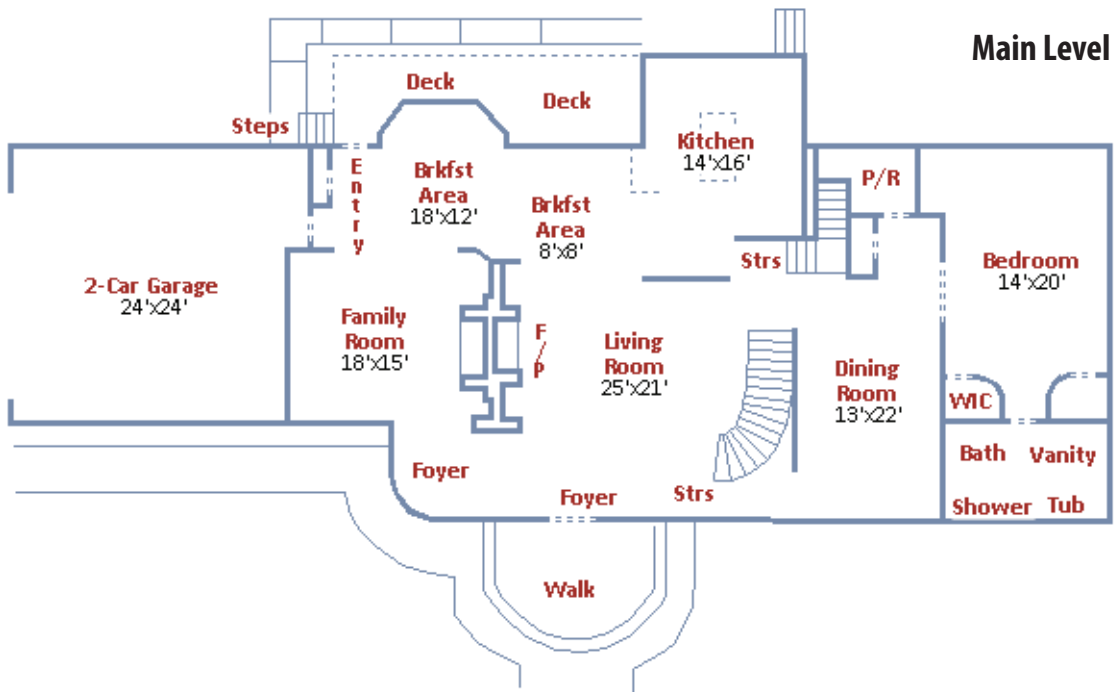



Exterior (Front)



Exterior (Front)



View from Front



Exterior (Front)

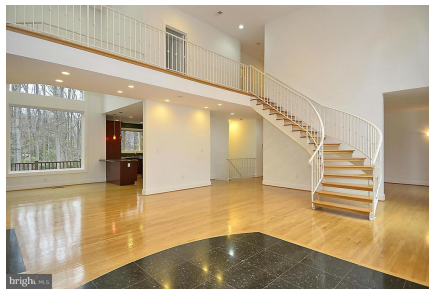

Foyer



Foyer View from Above

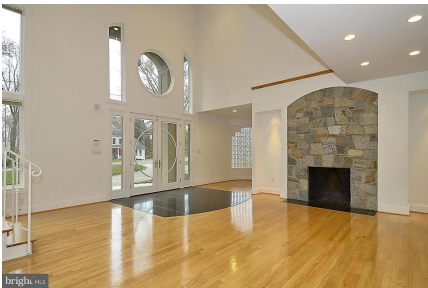

Living Room

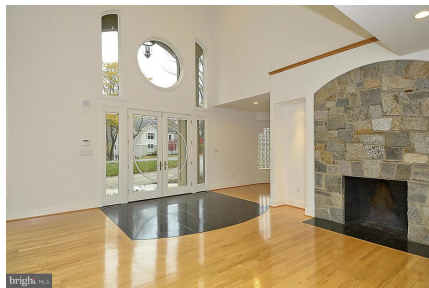

Foyer



Dining Room



Kitchen



Kitchen



Breakfast Area



Family Room



Second MBR Suite Main Level

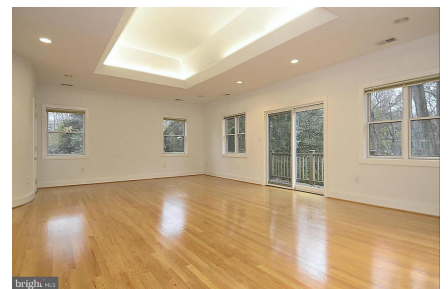

Bedroom (Master)



CIMENT & SHIELDS TEAM

Barbara Ciment, Associate Broker

LONG & FOSTER
REALTOR® REAL ESTATE

(C) 301-346-9126

(O) 301-424-0900

barbara@ciment.com

www.ciment.com





Bath (Master)

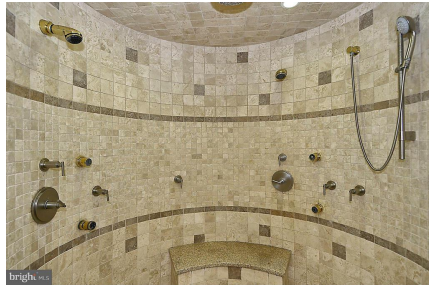

Bath (Master)

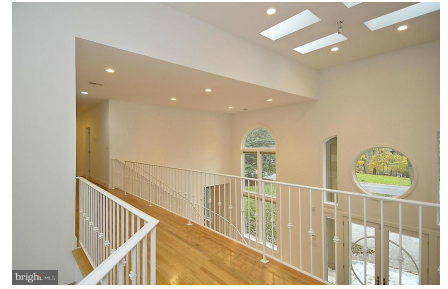

Upper Hall



Library



Bedroom 3



Bedroom 4



Game Room



Recreation Room



Nook in Recreation Room

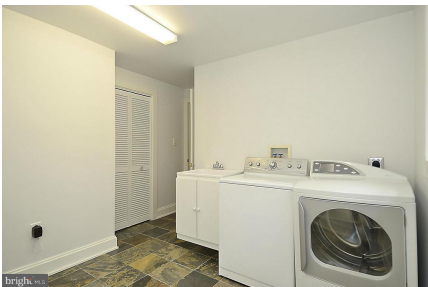

Daylight Laundry



Back Yard



Exterior (Rear)



View to Back



View to Back



Exterior (Rear)



CIMENT & SHIELDS TEAM

Barbara Ciment, Associate Broker

LONG & FOSTER REAL ESTATE

(C) 301-346-9126

(O) 301-424-0900

barbara@ciment.com

www.ciment.com

